

## **Aubrey J. Sheldon – WØEB**

**Dot Stabilizer Installation Instructions released to public domain 11/04/2023.**

**Vibroplex Champion, Lightning Bug and Vibroplex or Lionel WW2 Signal Corps J-36 Models with the flat rather than round pendulum arm. Shown is a Vibroplex Champion, but the Lightning Bug and J-36 use the same device.**

**Mount the stabilizer as shown in the photo with the setscrew on the back side of the pendulum. Get it as close to the mounting screw for the dot contact as possible without interfering with the contact mount and tighten the setscrew snugly with the supplied Allen wrench, but be careful not to damage the pendulum.**

**Adjust the wire tensioning device so that the wire damper hook is just touching the contact spring and doesn't interfere with either of the contacts, then lock it in place with the setscrew on top of the Aluminum block. Next, align the springy dot contact to center up on the fixed contact. This will change the timing and spacing so you will need to adjust both the fixed dot contact and the pivot arm dot stop for proper operation of the bug. If you need them, instructions can be found on the Vibroplex website [www.vibroplex.com](http://www.vibroplex.com). It would also be a good idea to clean the contacts before use to ensure the cleanest sounding signal.**

**Enjoy – Jim, W0EB**



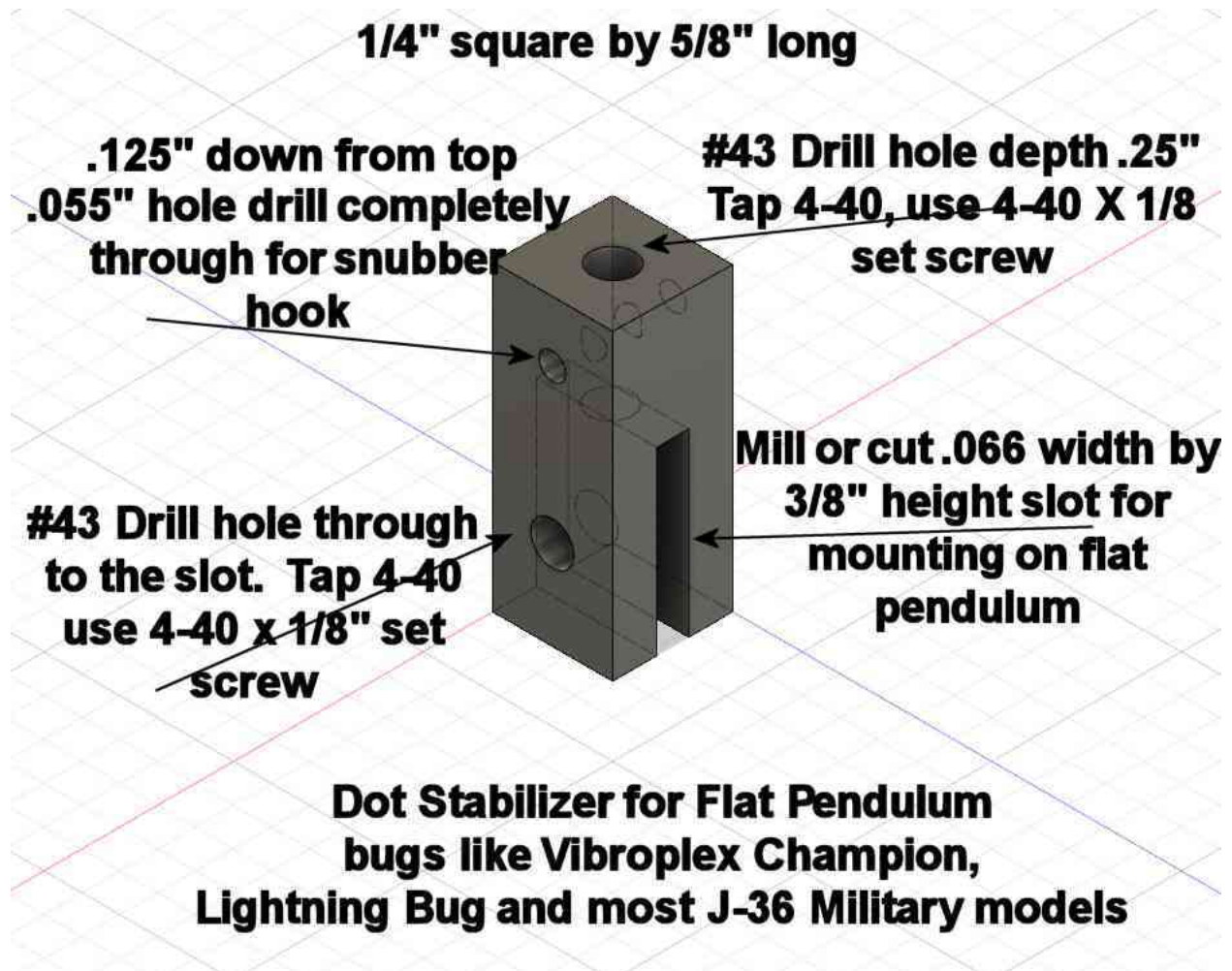

**The wire hook needs to be bent to a shape similar to that shown in the picture on page one and should be made from .055" diameter piano wire carefully bent to shape. Set screws are 4-40 by 1/8" and used to lock the snubber hook in position and also secure the device to the pendulum on the bug.**