

TSW Broadcast Band Filter for the HF Signals μ BITX Transceivers (All Versions)



Through hole and Surface mount BCB filters for the μ BITX Transceivers.

These Filters were designed to be high pass types with a low end cutoff frequency of approximately 2.0 MHz to keep AM broadcast station interference out of the μ BITX receiver's front end. They have proven to be very effective in doing just that. The only drawback is that it's no longer able to receive MW AM stations unless they are very strong and local as ALL frequencies below 2.0 MHz are effectively blocked. Since the μ BITX was not designed for AM reception (SSB/CW only), this isn't deemed to be a major problem for most μ BITX users.

The filter is connected in the receiver's RF input line between K1 and K3 by cutting that trace near K1 and soldering the outer two pins of J1 to the cut ends of that trace. The filter is symmetrical so it doesn't matter which end connects to K3 and which connects to K1. The center pin connects to a nearby ground pad in all cases.

Since all parts are readily available from many sources, TSW will only supply the PC boards on a cost plus postage basis and the user will need to supply the 2 RF chokes and 3 capacitors themselves. The parts list at the end of this document will have Tayda Electronics (for the discrete components) and Mouser (for the SMD components) part numbers to make it easier to find the same ones TSW used in constructing the examples shown.

Construction: Discrete Component version.

1. Install the two 1.8 microhenry RF chokes at L1 and L2. Solder and check all connections and trim the leads
2. Install the two 820 Picofarad capacitors at C1 and C3. Solder and check all connections and trim the leads. (The pads are laid out to take both 2.5 and 5.0 mm lead spacings. If using the smaller 2.5 (.1") spacing, use the center and bottom hole of each set of pads.)
3. Install the 470 Picofarad capacitor at C2 using the left and center holes for 2.5mm spaced capacitors and the left and right pads for the 5.0mm size.

NOTE: The silkscreen shows the outlines of the two sizes of capacitors to aid in determining which holes to use.

4. If a 3 pin connector is used at J1, solder it through the 3 holes with the connector body on the non-component side of the board. Solder the 3 pins and check to make sure there are no shorts. When connecting to the μ BITX as long as the center pin of J1 is grounded, it does not matter which of the other two pins are used input or output connections as the filter is totally symmetrical and either can be used as input or output.

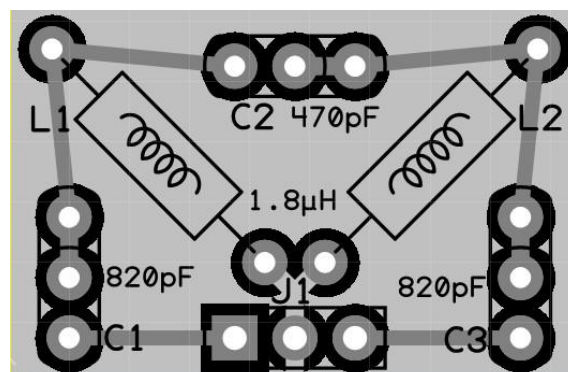

Construction: Surface Mount version.

1. Apply a small amount of solder to one pad for each of the following components, L1, L2, C1, C2 and C3 to prepare the PCB to receive the parts.
2. Using a fine point tweezers, install a 1.8 microhenry SMD inductor at L1 by heating the pad containing the small amount of solder, make sure L1 is tight to the pad and let the joint cool. Now carefully solder the opposite end and check that both ends are properly soldered. Touch up if necessary.
3. Using the same technique, install the second 1.8 microhenry SMD inductor at L2 and check your work.
4. Using the same technique as for installing the inductors, install the 3 SMD capacitors. 820 picofarad 0805 size ceramic capacitors at C1 and C3 plus a 470 picofarad 0805 size ceramic capacitor at C2. Carefully check to insure both ends of all the capacitors are properly soldered.
5. Finally, see step 4 in the Discrete Component instructions above and install J1 (if used).

The SMD version is installed in the μ BITX the same way you would install the Discrete Component version and is explained at the beginning of this manual.

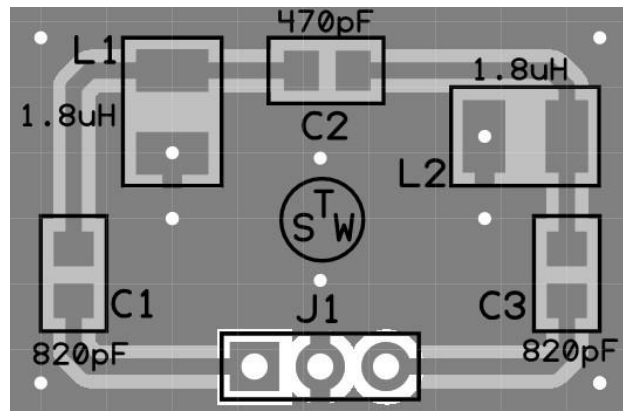

Appendix A: Schematic (same schematic for both versions).

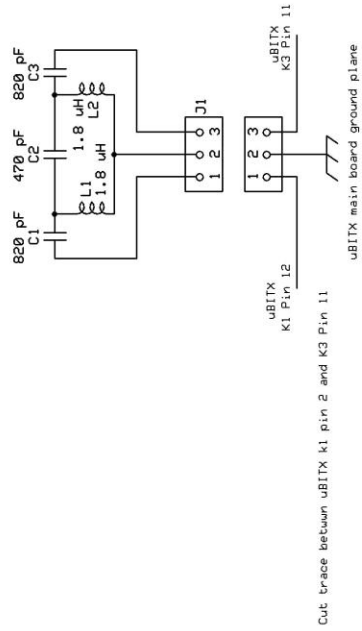

Solder 3 pin male header between the two sides of the cut trace
Pin 1 to the trace going to uBITX K1 pin 12
Pin 2 to the uBITX ground plane between the cut ends of the trace
Solder Pin 2 on the underside of the main uBITX PCB

Triumvirate Skonk Worx	
uBITX BCB Filter	
Unknown	Rev 1.0 4/2/2020
Sheet 1 of 1	

Appendix B: Parts List

Discrete Component parts:

___ L1, L2	1.8 uH inductor	Tayda SKU-A447
___ C1, C3	820 pF 50V monolithic capacitor	Tayda SKU: A-1446
___ C2	470 pF 50V monolithic capacitor	Tayda SKU: A-1363
___ J1	3 pin connector, user determined/supplied	
___ PCB	TSW Discrete Component PCB, V2.0	

Surface Mount Component Parts:

___ L1, L2	1.8 uH SMD inductor	Mouser 652-CMH322522-1R8KL
___ C1, C3	820 pF 50V C0G 0805	Mouser 80-C0805X821J5G7800
___ C2	470 pF 50V C0G 0805	Mouser 80-C0805X471J1G7800
___ J1	3 pin connector, user determined/supplied	
___ PCB	TSW Surface Mount Component PCB, V2.0	